

HOW TO ORDER

ESWHEE	-G	03	-C2	-75	-D24	-K31	-A1
Series	Mounting Style	Nominal Size	Spool Type	Nominal Flow	Supply Voltage	Connector	Command Value
Proportional directional valve, Direct operated, close loop, with integrated electronics	Subplate Mounted	03:10mm	①	25:25L/min 50:25L/min 75:75L/min	D24:DC24V	No code: with amplifier connector K31: without	A1: ±10V F1: 4-20mA

① List of Spool Configurations

Application	Spool Type	Symbols	Application	Spool Type	Symbols
4-way, 3-position	C2		4-way, 2-position	C2B	
	C21			C4B	
	C30			C2BS	
	C40			C4BS	
	C41				

Remarks: spool type C21, C41, rated flow ratio of P-A and B-T is 2:1, P-B and A-T is 1:2



Technical Data

Nominal Size	G03(10mm)
Installation Position	any, preferably horizontal
Storage temperature range	-15 to 80°C
Ambient temperature range	-15 to 70°C
Weight	6.5kg

● Hydraulic(measured with P=100bar, VG46, 90l = 40 ± 5 °C

Maximum operating pressure	PortA, B, P 315 bar PortT 210 bar
Nominal flow (ΔP=10bar)	25, 50, 75L/min
Maximum flow	180L/min
Hydraulic fluid	Mineral Oil
Viscosity range	20 to 380mm ² /s (preferably 30...46)
admissible degree of contamination of the hydraulic fluid	Maximum admissible degree of contamination of the hydraulic fluid, cleanliness class 9 according to NAS 1638 (c) and Class 20/18/15 according to ISO 4406 (c)
Hysteresis	≤ 0.1%
Range of inversion	≤ 0.05%
Response Sensitivity	≤ 0.05%
Zero temperature drift	0.15%/10K 0.1%/100 bar

Electrical

Rated current	2.5A
Solenoid coil resistance	Cold value 3.3Ω Maximum hot value 5.55Ω
Actuated time	ED100%
Maximum coil temperature	150°C
Protection class	IP65

Amplifier

Type	Digital
Supply Voltage	DC24V(19-35V)
Power Consumption	<45VA
Current Consumption	<2A
Command Value	±10V(Re>50KΩ) or 4-20mA(Re<200Ω)
Measuring output Actual Value	±10V(IL<2mA) or 4-20mA(RL<200Ω)
Electrical connection	Connector (according to DIN EN 175201-804)
Protection class	IP65



Electrical Connection

● Connector(According to DIN EN 175201-804)

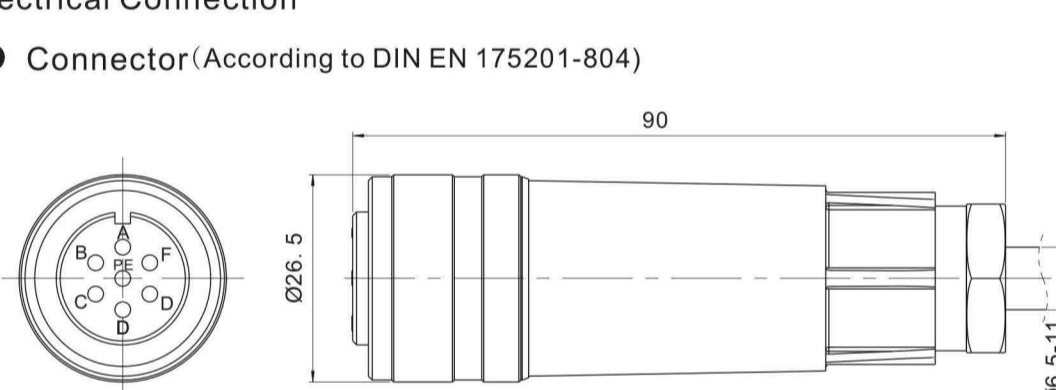

Pin Assignment

Contact	Function	-A1 voltage type	-F1 Current type
A	Power Supply	DC24V(19-35V)	
B		0V	
D	Differential amplifier input (command value)	±10V(Re>50KΩ)	4-20mA(Re<200Ω)
E		Reference Potential command value	
F	Measuring output (actual value)	±10V(IL<2mA)	4-20mA(RL<200Ω)
C		Reference Potential actual value	
PE	Earthing	Connected to the valve side cover and housing	

Command value:

Positive command value (0...+10 V or 12...20 mA) at D and reference potential at E result in flow from P → A and B → T

Negative command value (0...-10 V or 12...4 mA) at D and reference potential at E result in flow from P → B and A → T

With control spool type C*B, a positive command value at D and reference potential at E (0 to +10V or 4 to 20mA) result in flow from P → B and A → T;

With control spool type C*BS, with same condition, it results in P → A and B → T

Actual Value:

Actual value 0 ... +10 V (or 12 ... 20 mA) at F and reference potential at C result in flow from P → A and B → T.

Actual value 0 ... -10 V (or 4 ... 12 mA) result in flow from P → B and A → T.

With control spool type C*B, a positive actual value 0 ... +10V (or 4 ... 20 mA) result in flow from P → B and A → T.

With control spool type C*BS, a positive actual value 0 ... +10V (or 4 ... 20 mA) result in flow from P → A and B → T.

Notice:Electrical signals provided via control electronics (e. g. actual value) must not be used for switching off safety-relevant machine functions.



Connection cable: Recommendation

Up to 25m cable length type LIYCY 5 x 0.75 mm²

Up to 50m cable length type LIYCY 5 x 1.0 mm²

External diameter 6.5 ... 11 mm, Connect shield on PE only on the supply side

Amplifier Internal Diagram

