

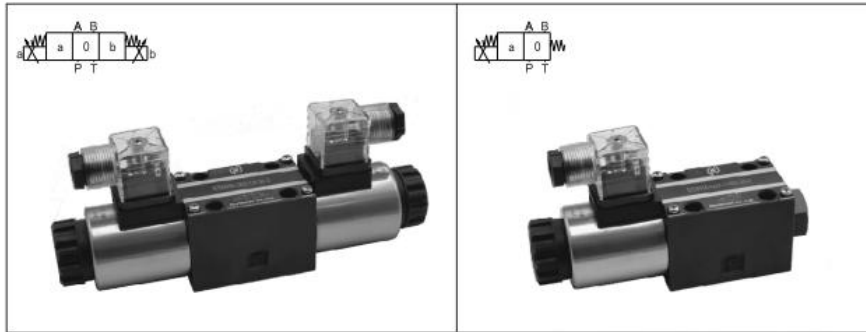

## ESWHA-G02 PROPORTIONAL DIRECTIONAL VALVE



### HOW TO ORDER

ESWHA	-G	02	-C2	-30	-K4	-1
Series	Mounting Style	Nominal Size	Spool Type	Nominal Flow	Connector	Rated Current
Proportional directional valve, Direct operated, open loop, without integrated electronics	G: Subplate Mounted	02:6mm	①	07:07L/min 15:15L/min 30:26L/min	No code: with K4: without	1: 1, 5A 2: 2, 5A

#### ① List of Spool Configurations

Application	Spool Type	Symbols	Application	Spool Type	Symbols
4-way, 3-position	C2 C21		4-way, 2-position	C2B	
	C30			C4B	
	C40 C41			C2BS	
				C4BS	
Remarks: spool type C21, C41, rated flow ratio of P-A and B-T is 2:1, P-B and A-T is 1:2					



■ Technical Data

Nominal Size	G02(6mm)
Installation Position	any, preferably horizontal
Storage temperature range	-15 to 80°C
Ambient temperature range	-15 to 70°C
Weight	2.0kg

● Hydraulic(measured with P=100bar, VG46, 9Öl = 40 ±5 °C

Maximum operating pressure	Port A, B, P 315 bar Port T 210 bar
Nominal flow (ΔP=10bar)	07, 15, 26L/min
Maximum flow	42L/min
Hydraulic fluid	Mineral Oil
Viscosity range	20 to 380mm <sup>2</sup> /s (preferably 30...46)
admissible degree of contamination of the hydraulic fluid	Maximum admissible degree of contamination of the hydraulic fluid, cleanliness class 9 according NAS 1638 (c) and Class 20/18/15 according to ISO 4406 (c)
Hysteresis	≤5%
Range of inversion	≤1%
Response sensitivity	≤0.5%

● Electrical

Type	ESWHA-G02-* -1	ESWHA-G02-* -2
Rated current	1.5A	2.5A
Solenoid coil resistance	Cold value 5Ω Maximum hot value 7Ω	Cold value 2Ω Maximum hot value 3Ω
Actuated time	ED100%	
Maximum coil temperature	150°C	
Electrical connection	Connector (according to DIN EN 175301-803 and ISO 4400)	
Protection class	IP65	

■ Electrical connection

