



Reliability & Satisfaction

SW-G06 Pilot Operated Valve External and Internal Pilot Pressure and Drain

The **SW-G06** series valve (NFPA D08) can be configured to be either internally or externally piloted and to be either internally or externally drained. The part numbering system identifies the design, for example:

SW-G06-C6-A120-10 identifies a 4-way, 3-position, tandem center, pilot-operated valve for AC 120 Volt with a junction box electrical connection – and with **internal pilot** and **internal drain**.
(Note, the X & Y ports on the manifold surface of the valve must be plugged.)

SW-G06-C6-E-A120-10 identifies the valve with **external pilot** and **internal drain**.
(Note, the Y port on the manifold surface of the valve must be plugged; the X port provides the external pressure.)

SW-G06-C6-T-A120-10 identifies the valve with **internal pilot** and **external drain**.
(Note, the X port on the manifold surface of the valve must be plugged; the Y port drains the valve.)

SW-G06-C6-E-T-A120-10 identifies the valve with **external pilot** and **external drain**.
(The subplate X port provides the external pressure; the Y port drains the valve.)

At times it is desired to convert the pilot or drain configurations in the field.

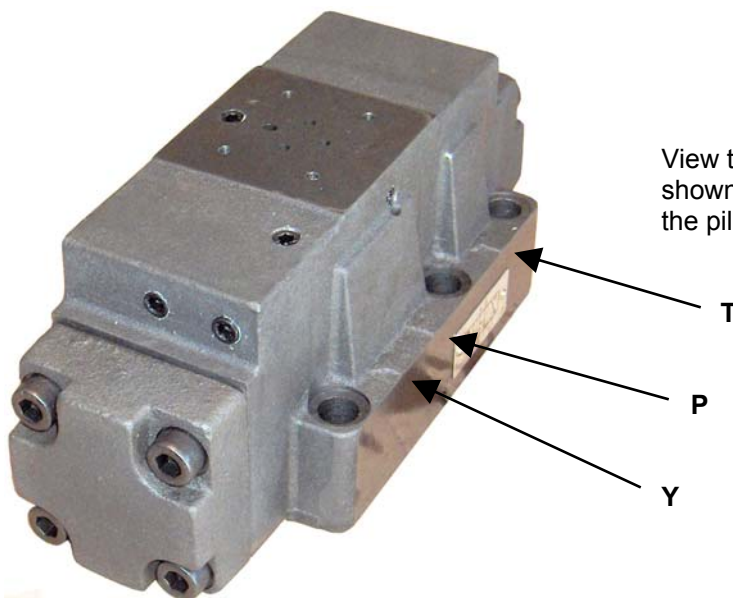

View the valve in the orientation shown. (The valve is shown without the pilot valve.)

Y, P, and T
are the letters
on the casting.)

The positioning of the plugs in the body are shown as present or absent for the desired internal or external function.

The two plugs identified on the top surface of the valve are in access ports to the pilot and drain passages.

Remove the top surface plugs for access to the control points for internally or externally piloting or draining the valve, as shown.

Whichever configuration is chosen (i.e., with the deep plug in for external function or out for internal function), the top surface plug must be installed for operation of the valve.

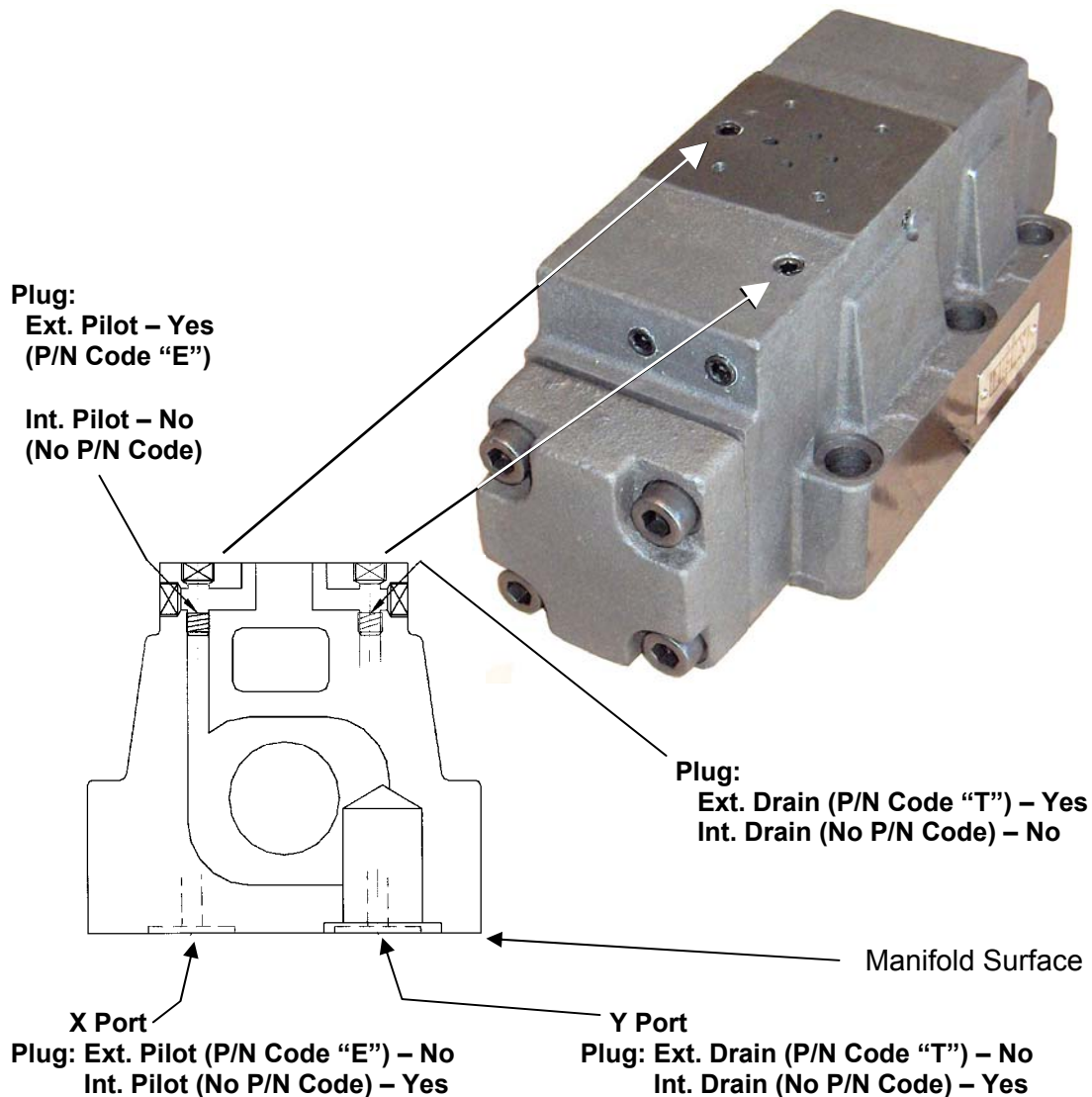

At conversion, the one plug that is removed may be used as the other required plug.